

Job name:	Date:
Scheduled Reference:	Contractor:

System Information



AHRI number	\	217287926
Outdoor Model	\	WLUD36W/A-D(U)
Indoor Model	\	WLCAT36F/NaA
System Rating		
Cooling Capacity	Btu/h	32600
Heating Capacity	Btu/h	34000
Power Supply	V	208-230V/1Ph/60Hz
SEER2	\	15.2
EER2	\	9.5
HSPF2	\	8.5
Gas Pipe	inch (mm)	3/4 (19)
Liquid Pipe	inch (mm)	3/8 (9.52)
Standard Pipe Length	ft (M)	24.6 (7.5)
MAX. refrigerant pipe length between Indoor and Outdoor	ft (M)	164 (50)
MAX. Vertical Height difference between Indoor and Outdoor	ft (M)	49.2 (15)
Connection Method	\	Screw Connection (standard)
Refrigerant Type	\	R410A



Features:

- High efficiency DC Inverter Technology
- Compact and quiet side discharge unit
- Match with TrueNorth or 3rd party indoor unit
- 24V thermostat compatible
- Low ambient cooling to 5°F (-15°C)
- Low ambient heating to -22°F (-30°C)



Outdoor Data and Dimensions

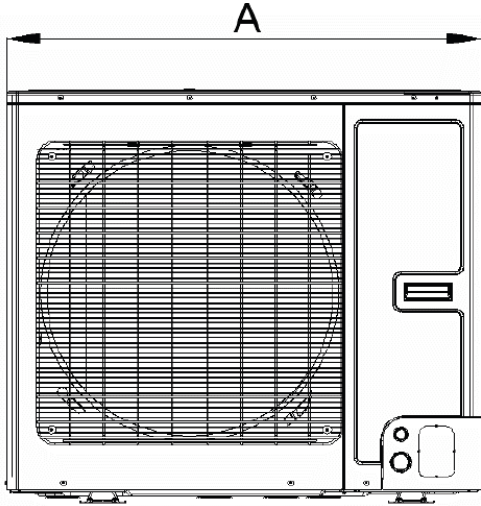

Outdoor Unit Data		
Sound Pressure Level	dB(A)	53.5(45 Min - 62 Max)
Min/Max Voltage	V	187-253
Control Voltage	V	24
Rated Current Cooling	A	13
Rated Current Heating	A	17
MCA	A	24
MOP	A	35
Dimension (HxWxD)	inch (mm)	32 1/4 x 37 x 18 1/8 (820 x 940 x 460)
Net Weight	lb (Kg)	217.2 (98.5)
Gross Weight	lb (Kg)	240.3 (109)
Operating Temperature for Cooling	°F/°C	5~129.2 (-15~54)
Operating Temperature for Heating	°F/°C	-22~75.2 (-30~24)

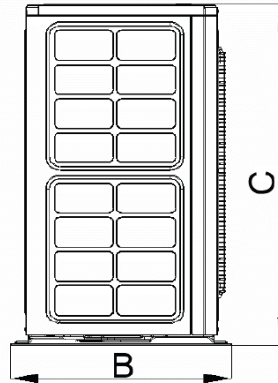
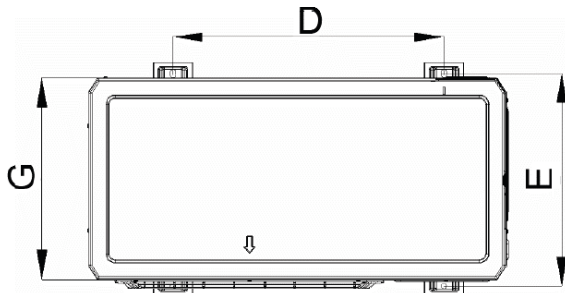

Dimensions	
A	37
B	20 1/8
C	32 1/4
D	24
E	19 1/8
G	18 1/8

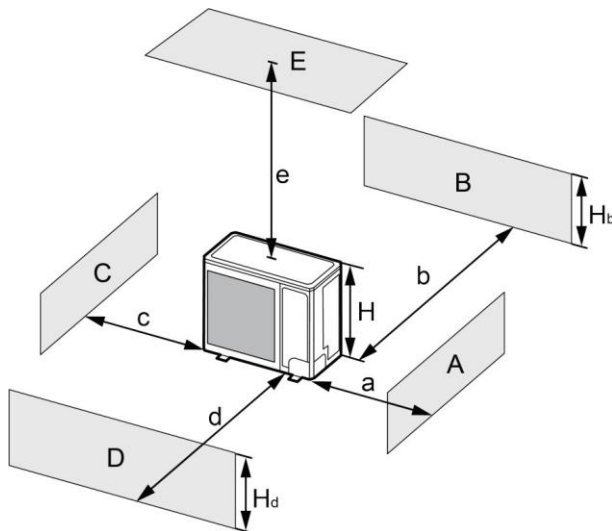

A~E	H _b	H _d	H	(in)				
				a	b	c	d	e
B	—	—	—	-	≥ 4	-	-	-
A,B,C,	—	—	—	≥ 12	≥ 4	≥ 4	-	-
B,E	—	—	—	-	≥ 4	-	-	≥ 40
A,B,C,E	—	—	—	≥ 12	≥ 6	≥ 6	-	≥ 40
D	—	—	—	-	-	-	≥ 40	-
D,E	—	—	—	-	-	-	≥ 40	≥ 40
B,D	H _b < H _d	H _d > H	-	≥ 4	-	≥ 40	-	-
	H _b > H _d	H _d < H	-	≥ 4	-	≥ 40	-	-
B,D,E	H _b < H _d	H _b ≤ 1/2H	-	≥ 10	-	≥ 80	≥ 40	-
		1/2H < H _b ≤ H	-	≥ 10	-	≥ 80	≥ 40	
	H _b > H	Prohibited						
	H _b > H _d	H _d ≤ 1/2H	-	≥ 4	-	≥ 80	≥ 40	-
		1/2H < H _d ≤ H	-	≥ 8	-	≥ 80	≥ 40	-
H _d > H	Prohibited							

Specifications are subject to change without notice. Manufacturer reserves the right to discontinue or modify specifications or designs without notice or without incurring obligations. All Rights reserved.

Indoor data and Dimensions

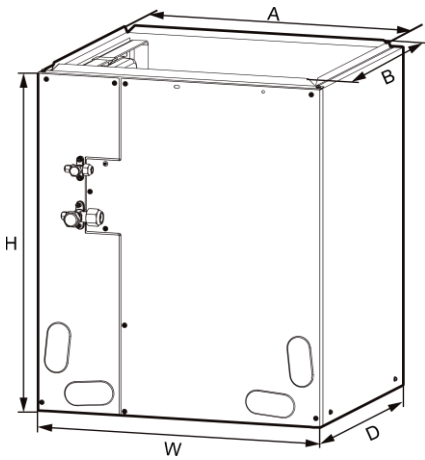

Indoor Unit Data		
Air Flow Volume	CFM (m ³ /h)	1000 (1700)
ESP	in.w.g (Pa)	0.0~1.0 (0~250)
Evaporator Fin per Inch	-	18
Evaporator Number of Circuit	-	12
Throttling Method	-	Thermal Expansion Valve
Dimension (HxWxD)	inch (mm)	23 x 17 1/2 x 21 1/4 (584 x 445 x 540)
Refrigerant Type	-	R410A
Refrigerant Charge	oz(Kg)	8.82 (0.25)
Net Weight	lb (Kg)	64 (29)
Gross Weight	lb (Kg)	75 (34)
Operating Temperature for Cooling	°F/°C	64.4~80.6 (18~27)

Unit: inch(mm)

Model	Dimension				
	W	D	H	A	B
WLCAT24F/NaA	17-1/2(445)	21-1/4(540)	23(584)	15-7/8(403)	19-3/8(492)
WLCAT36F/NaA	17-1/2(445)	21-1/4(540)	23(584)	15-7/8(403)	19-3/8(492)
WLCAT48H/NaA	24-1/2(622)	21-1/4(540)	28-1/2(724)	22-7/8(581)	19-3/8(492)
WLCAT60H/NaA	24-1/2(622)	21-1/4(540)	28-1/2(724)	22-7/8(581)	19-3/8(492)

Optional Smart thermostat bundle

WK-010WC1

WK-010WD1

